

# FUELCO LTKD7

## Diesel Fuel Tank



<b>Product Name</b>	<b>KUBE LTKD7</b>
<b>Manufacturer</b>	Fuelco
<b>Category</b>	Diesel Fuel Tank

## TECHNICAL SPECIFICATIONS

<b>Tank Specifications</b>	
Tank Capacity (L)	<b>7200 L</b>
Safe Fill (L)	<b>6840 L</b>
Shape	<b>Rectangular</b>
Tank Body Material	<b>Self-bunded carbon steel</b>
Lifting Points	<b>Included for crane handling</b>
Channel Support	<b>2 x suitable channels</b>
Compartments	<b>Single compartment</b>
Manhole	<b>Secure manway for cleaning and inspections</b>
Wall Type	<b>Double wall</b>
<b>Extras</b>	
Fork Pockets	<b>Double-sided access</b>
Baffled Internally	<b>To restrict product movement</b>
Galvanized Edge	<b>Prevents nicks and damage</b>

# FUELCO LTKD7

Diesel Fuel Tank



## WEIGHTS & DIMENSIONS

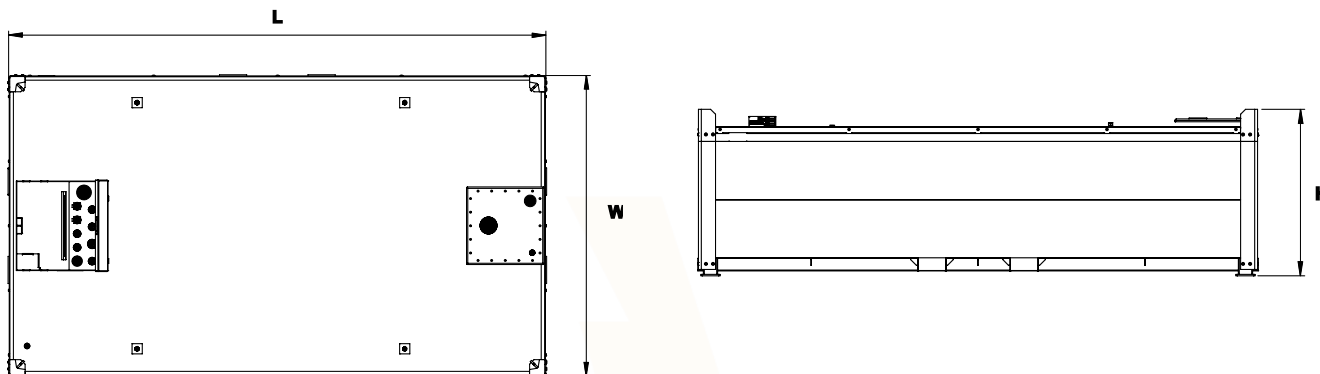

Length (L) mm	Width (W) mm	Height (H)mm
3945 mm	2210 mm	1194 mm

Dry Weight (kg)	
Dry Weight	2280 kg

[www.rentalgp.com](http://www.rentalgp.com)

©2024 Glow Power Equipment Rental LLC

All rights reserved.

This publication is based on datasheets from respective manufacturers and is intended for informational purposes only. All trademarks and proprietary materials belong to their owners. Glow Power holds no rights to the technical data presented and does not intend to infringe upon copyrights or trademarks.